

SINGLE ASSIGNED USER

Aspire locks with a keypad interface, single assigned user, are operated by a 4-digit User Code or by an ADA compliant User Key. Manager Keys provide management access and external power. Programming is accomplished via a Programming Key unique to the lock system. An optional mobile application tool simplifies lock system management and provides audit trail for locks with advanced functionality.

LOCK PARTS

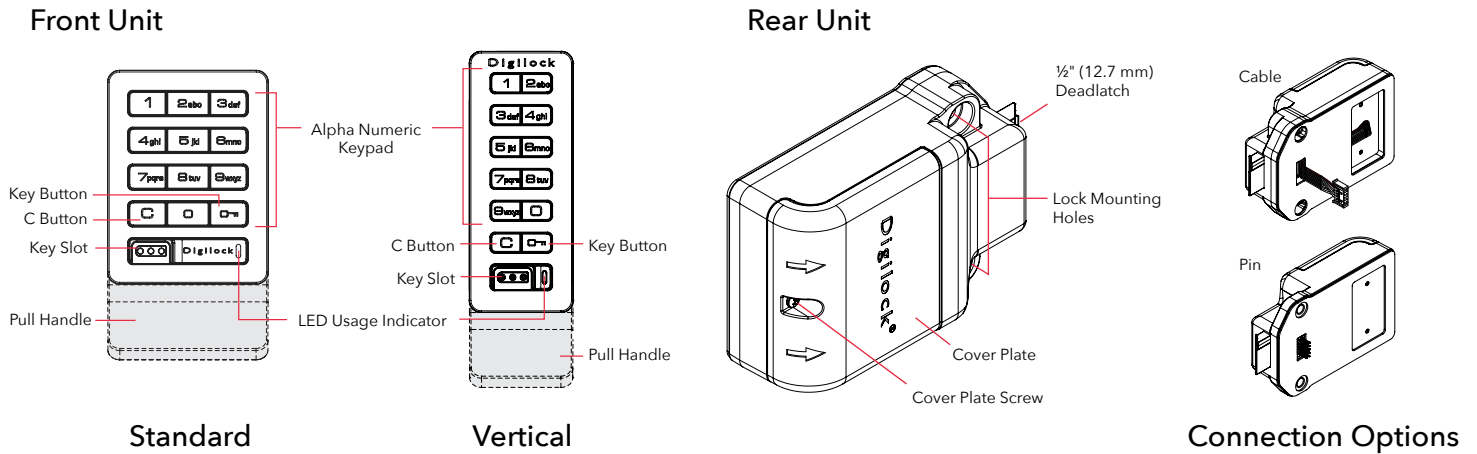

KEYS

	User Key	Manager Key ¹	Programming Key ²
Operates the lock	•	•	•
Overrides user access		•	•
Allows management inspection		•	•
Provides external power		•	•
Programs Manager Keys			•
Assigns user credentials ³		•	

¹ Up to 25 Manager Keys may be programmed to each lock. If managed with the optional Mobile App, up to 250 Manager Keys may be programmed to each lock.

² 1 Programming Key allowed per lock system.

³ One user credential may be assigned to each lock.

KEY INSERTION

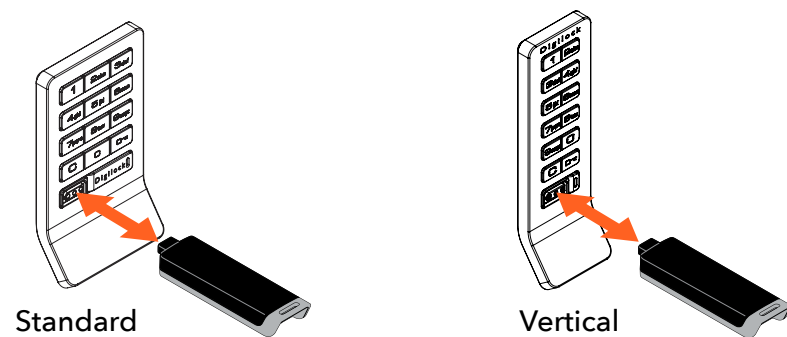

Refer to the above image for proper key insertion.

SETUP

Locks are shipped with factory default settings (only operates by pressing **C** **0π**). Each lock must be setup to operate with a Programming Key and Manager Keys.

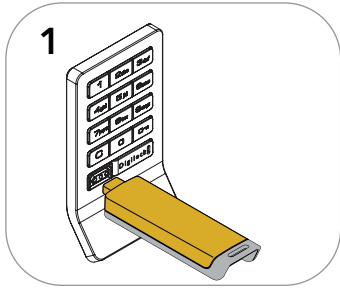

1
Insert the Programming Key.
A two-tone beep will be heard and the LED will turn on.

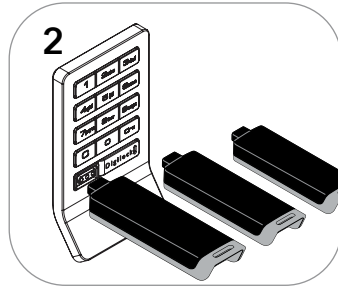

2
Insert one Manager Key at a time.
A two-tone beep will be heard for each Manager Key programmed.

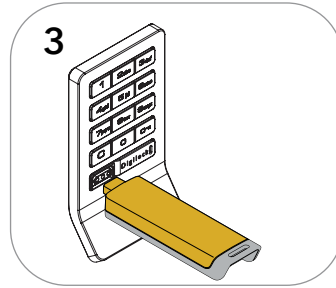

3
Insert the Programming Key.
A two-tone beep will be heard and the LED will turn off.

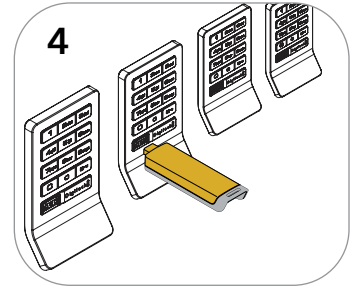

4
Repeat above steps for each lock or follow instructions to [Express Register Manager Keys](#) to setup all locks.

PROGRAMMING INSTRUCTIONS

Express Register Manager Keys

The Programming Key can quickly program multiple locks to operate with the same Manager Keys.

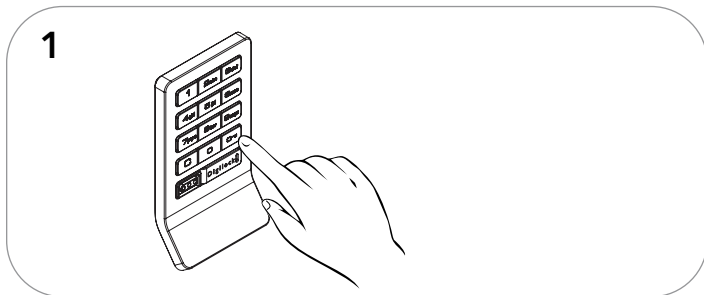

1
Go to a lock already programmed to operate with the Manager Keys.

Press **C** **0π** **6** **1** **0π**.

The LED will turn on.

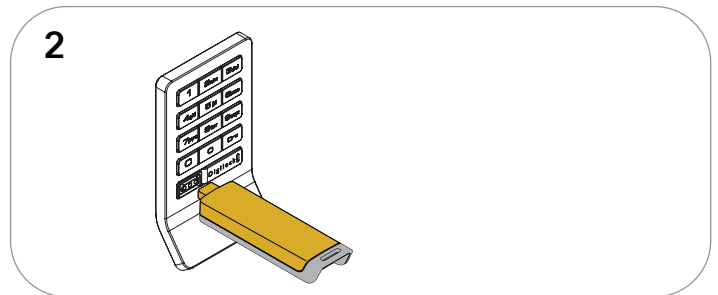

2
Insert the Programming Key.
A two-tone beep will be heard and the LED will turn off.

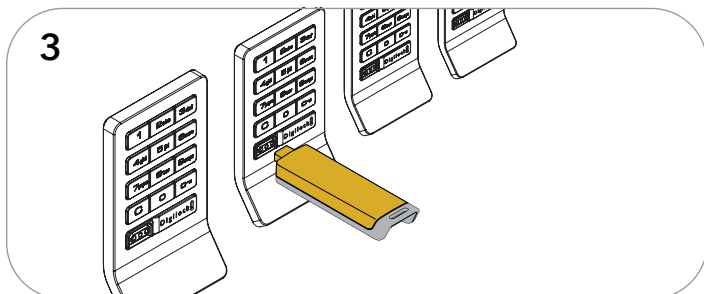

3
Insert the Programming Key to program each lock to operate with the same Manager Keys.

Two sets of two-tone beeps will be heard and the LED will flash twice to indicate successful programming.

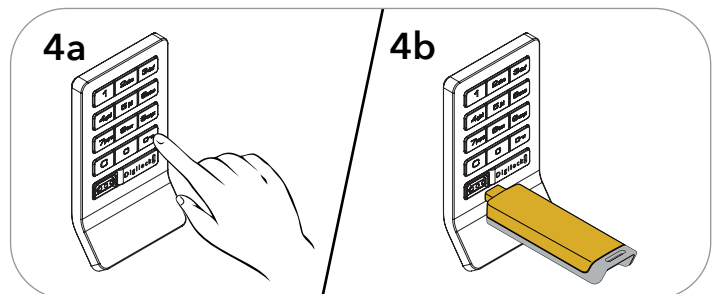

4a
End express registration mode.*

Go to any programmed lock.

Press **C** **0π** then insert the Programming Key. The latch will retract and extend automatically.

*The Programming Key will continue to function in express registration mode until it is used to operate the lock.

PROGRAMMING INSTRUCTIONS

Add Manager Keys

Manager Keys can be programmed to the locks at any time.

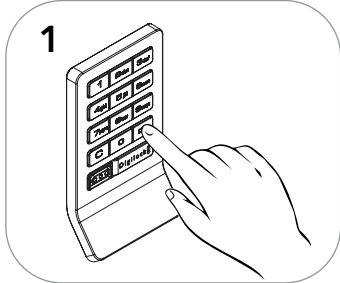

Go to a lock requiring additional Manager Keys.
Press **C** **0π** **5** **5** **0π**.
The LED will turn on.

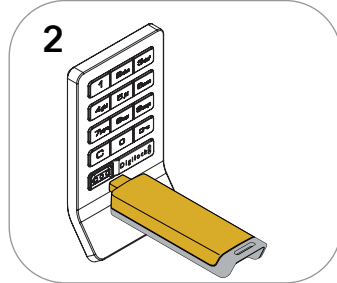

Insert the Programming Key.
A two-tone beep will be heard.

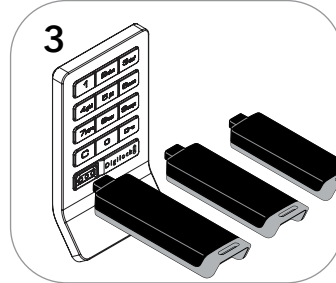

Insert each additional Manager Key one at a time.
A two-tone beep will be heard for each Manager Key programmed.

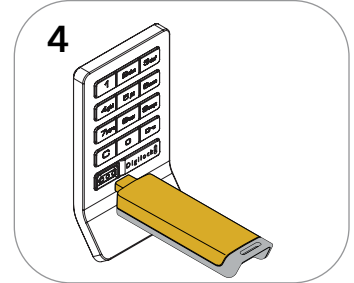

Insert the Programming Key.
A two-tone beep will be heard and the LED will turn off.
Repeat above steps for each lock or follow instructions to [Express Register Manager Keys](#) to quickly program multiple locks to operate with the same Manager Keys.

Replace Keys

The locks must be reprogrammed to prevent the lost/stolen keys from operating a lock.

To Replace the Programming Key

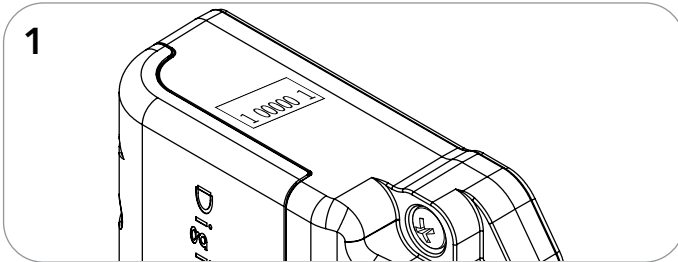

Note the order or serial number (found on the lock's rear unit).



Contact Digilock support to purchase a replacement Programming Key.

To Replace the Manager Keys

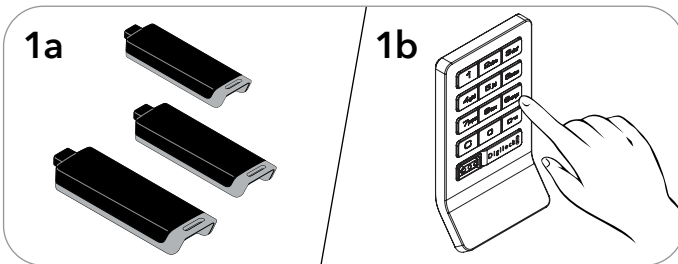

Collect all remaining and any new Manager Keys.
Go to any lock operated by the Manager Keys.
Press **C** **0π** **5** **5** **0π**.
The LED will turn on.

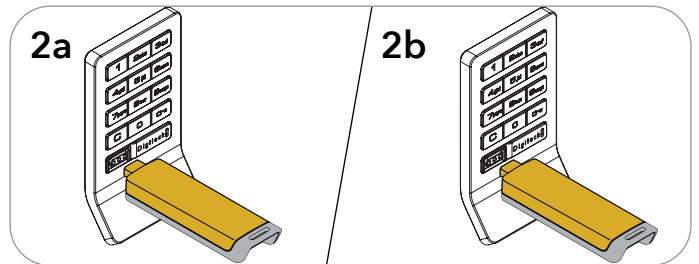

Insert the Programming Key.
A two-tone beep will be heard.
Insert the Programming Key again.
Three sets of two-tone beeps will be heard and the LED will turn off. All previously programmed Manager Keys will be erased.
Follow instructions to [Add Manager Keys](#) to program the remaining and replacement Manager Keys to the locks.

PROGRAMMING INSTRUCTIONS

Assign User Credentials

One user code (User Code or User Key) may be assigned to each lock.

Assign a User Code

1a

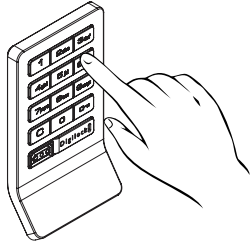

1b

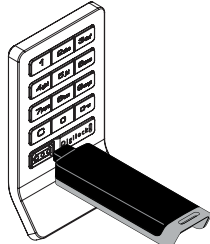

Press **C** **0π** **5** **5** **0π**.
The LED will turn on.
Insert a valid Manager Key.
A two-tone beep will be heard.

2a

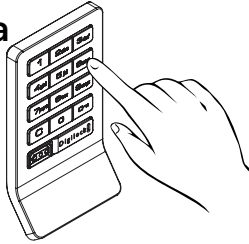

2b

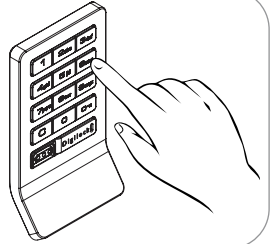

Press **C** **[new 4-7 digit code]** **0π**. A two-tone beep will be heard.
Press **C** **[the same 4-7 digit code]** **0π**.
Two sets of two-tone beeps will be heard and the LED will turn off.

Assign a User Key

1a

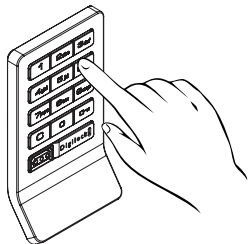

1b

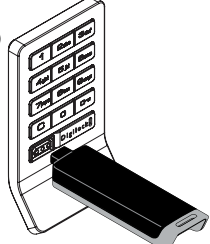

Press **C** **0π** **5** **5** **0π**.
The LED will turn on.
Insert a valid Manager Key.
A two-tone beep will be heard.

2

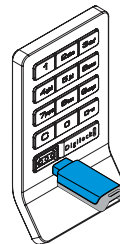

Insert a User Key.
Two sets of two-tone beeps will be heard and the LED will turn off.

OPERATION INSTRUCTIONS

In assigned use functionality, users operate the lock with their assigned user credential (either a User Code or a User Key).

Operate with an Assigned User Code

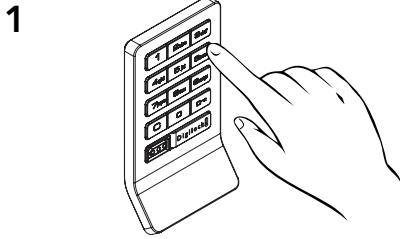

Unlock: Press **[C]** **[assigned 4-7 digit code]** **[0m]**.*

Relock: Close the door.

Operate with an Assigned User Key

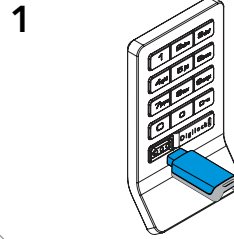

Unlock: Insert the assigned User Key.

Relock: Close the door.

Operate with a Manager Key

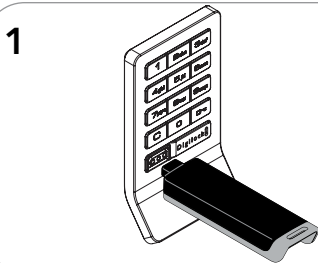

Unlock: Insert a valid Manager Key.

Relock: Close the door.

Operate with the Programming Key

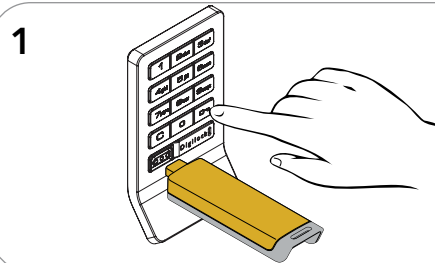

Unlock: Press **[C]** **[0m]** then insert the Programming Key.

Relock: Close the door.

*After 3 consecutive incorrect user code entries, the keypad will be disabled for 1 minute (Sleep Mode).

SUPPORT

Sleep Mode

After three consecutive incorrect User Code entries to unlock, the lock will go into "Sleep Mode" for one minute and for an additional minute for each subsequent incorrect entry. The keypad is disabled while in "Sleep Mode." A valid Manager Key may be used to unlock while the lock is in "Sleep Mode."

Error Condition Indicators

10 rapid beeps:

The lock is binding which means that either the door alignment or stored items are preventing the lock from operating. Press on the door while operating the lock. If error condition persists, contact Digilock support for assistance.

2 sets of three beeps:

The batteries are low. Replace the batteries.

Does Not Unlock with the User Code or User Key

The lock does not recognize the User Code or User Key. For immediate access, operate with a valid Manager Key. Follow instructions to [Assign the User Credentials](#) to assign the user credential to the lock.

Does Not Operate with a Manager Key

The lock does not recognize the Manager Key. Follow instructions to [Add Manager Keys](#) to program the Manager Key to the lock. For immediate access, operate with another valid Manager Key or with the Programming Key.

Does Not Operate with the Programming Key

The lock does not recognize the Programming Key. If the Programming Key has been replaced, operate with the Replacement Programming Key. Contact Digilock support for additional assistance.

No Audible Feedback when is Pressed

- The lock may be in "Sleep Mode" or the batteries may need to be replaced. For immediate access, operate with a valid Manager Key.
- The front unit may not be properly connected to the rear unit. Remove the lock from the door and check the connection.

BATTERY REPLACEMENT

It is not necessary to remove the lock from the door. In case of battery failure, operate with a valid Manager Key.

CAUTION: Risk of explosion or leakage if battery is replaced by an incorrect type, mixed with a different battery type, or inserted backwards. Replace all batteries of a set at the same time. Be sure to insert batteries with correct polarities. Remove exhausted batteries from the product promptly and dispose of used batteries according to the battery manufacturer's instructions.

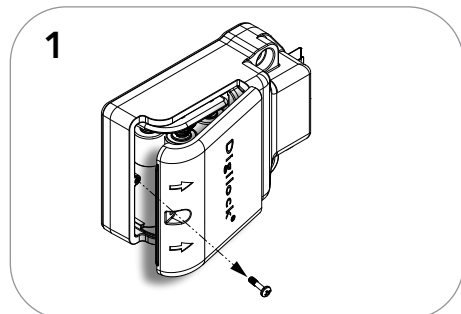

Remove the screw from the Cover Plate with a Phillips head screwdriver.
Remove the Cover Plate by lifting the tab at the edge of the cover, below the arrows.

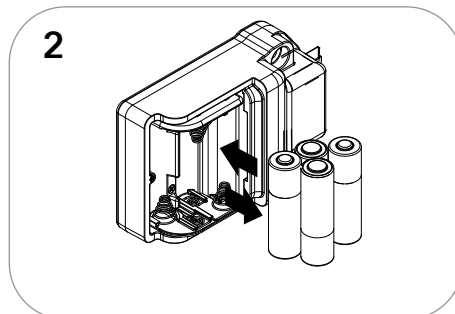

Remove the batteries from the housing. Replace with four premium alkaline AA batteries. Dispose of or recycle used batteries according to local regulations.

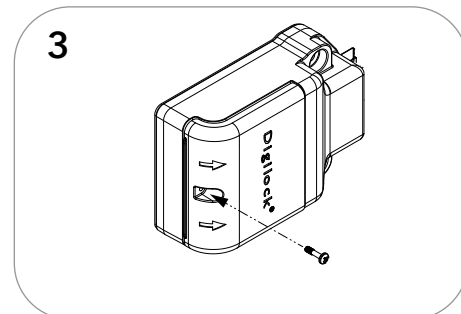

Replace the Cover Plate and secure with the screw.